

UML 1.4 Reference

Matthias Niete niete@oio.de
Dirk M. Sohn sohn@oio.de
Steffen Schluff schluff@oio.de

Orientation in Objects GmbH
Weinheimer Str. 68
68309 Mannheim
<http://www.oio.de>

General Purpose Concepts

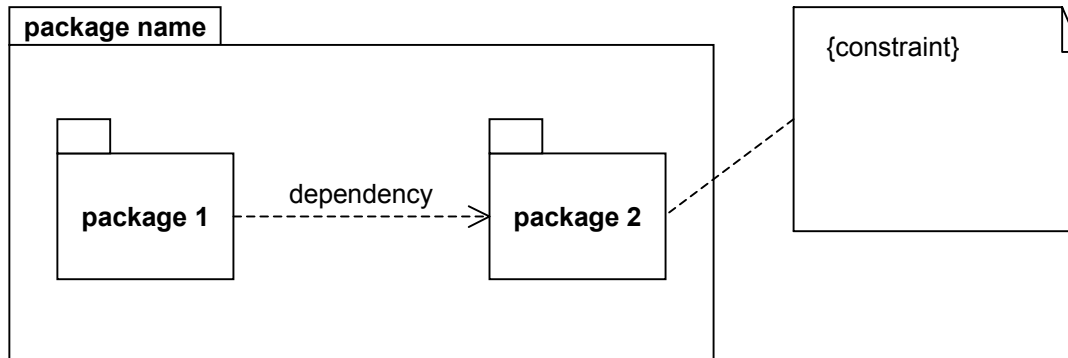
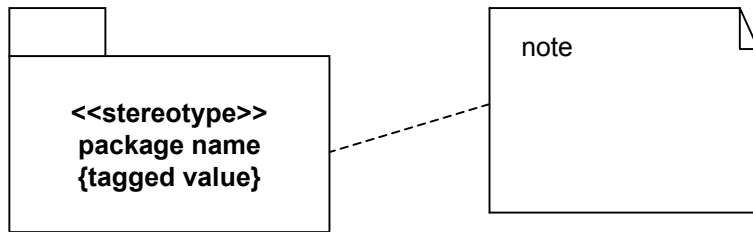

Class Diagram 1

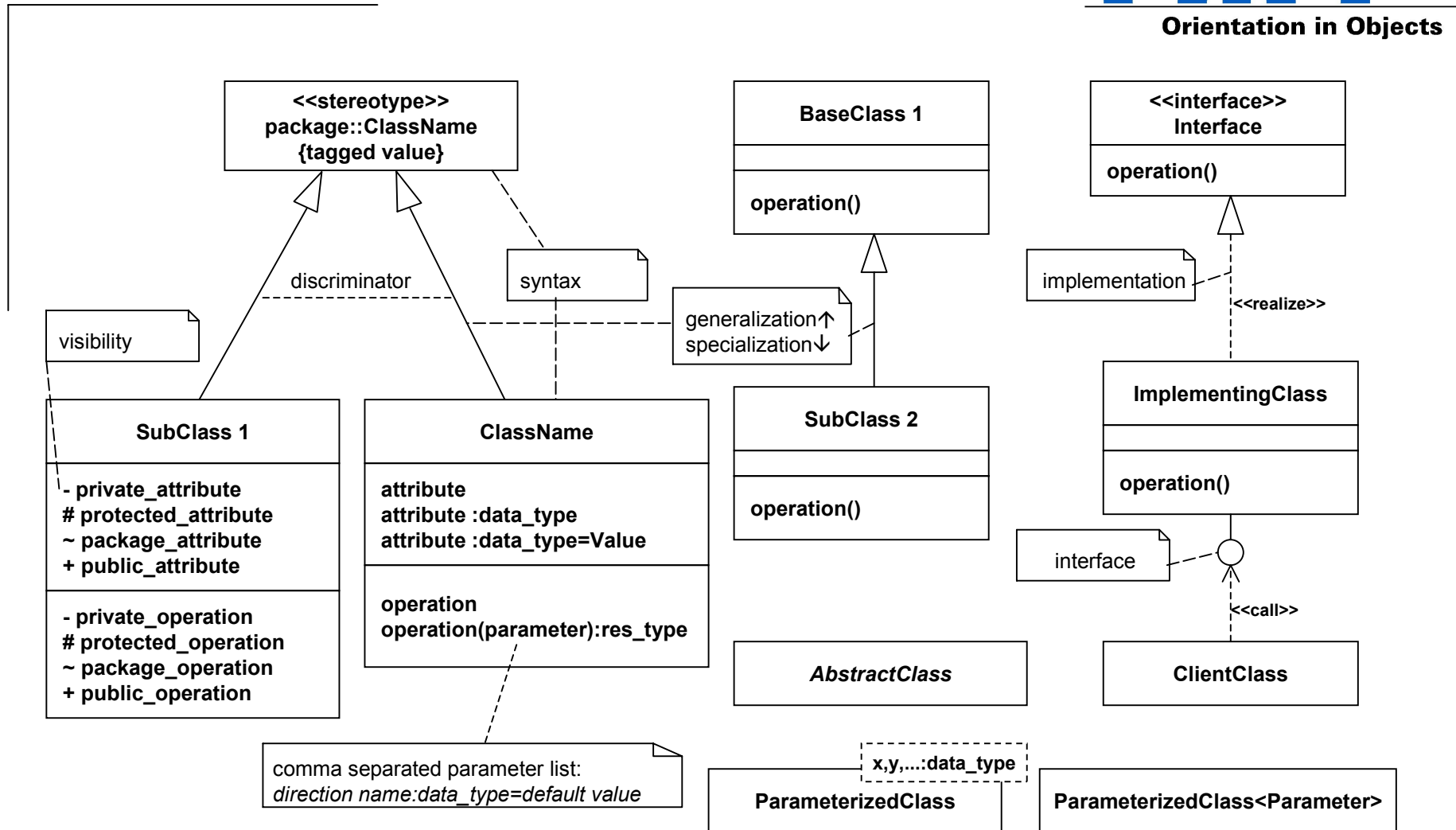

Class Diagram 2 (Associations)

Class Diagram



Orientation in Objects

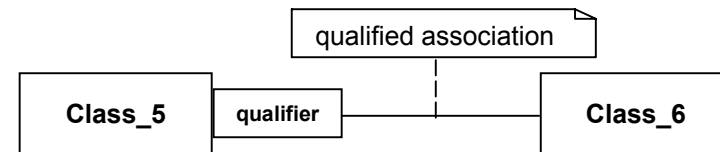
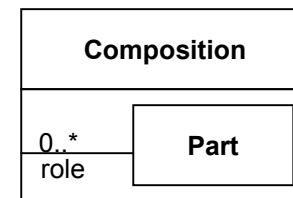
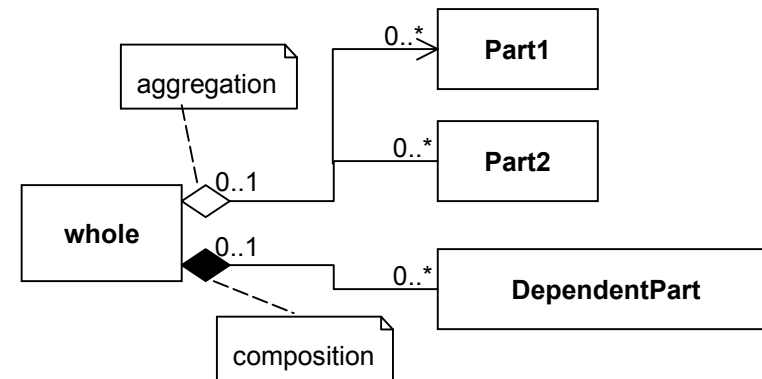
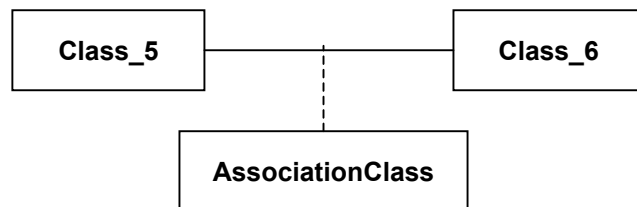
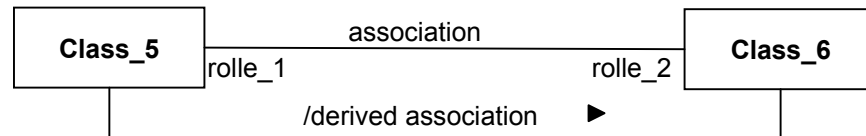
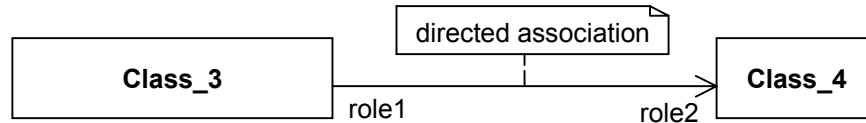
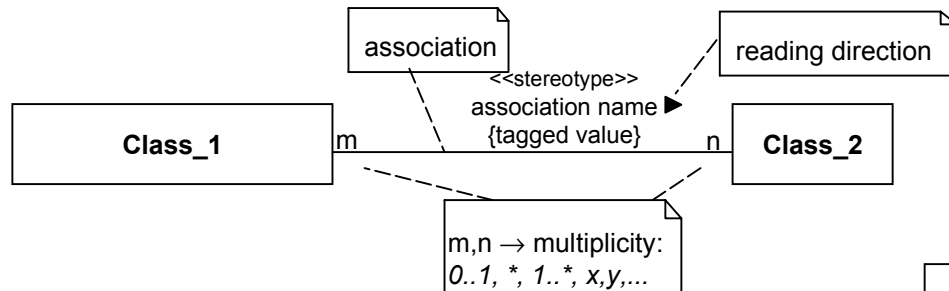

Use Case Diagram

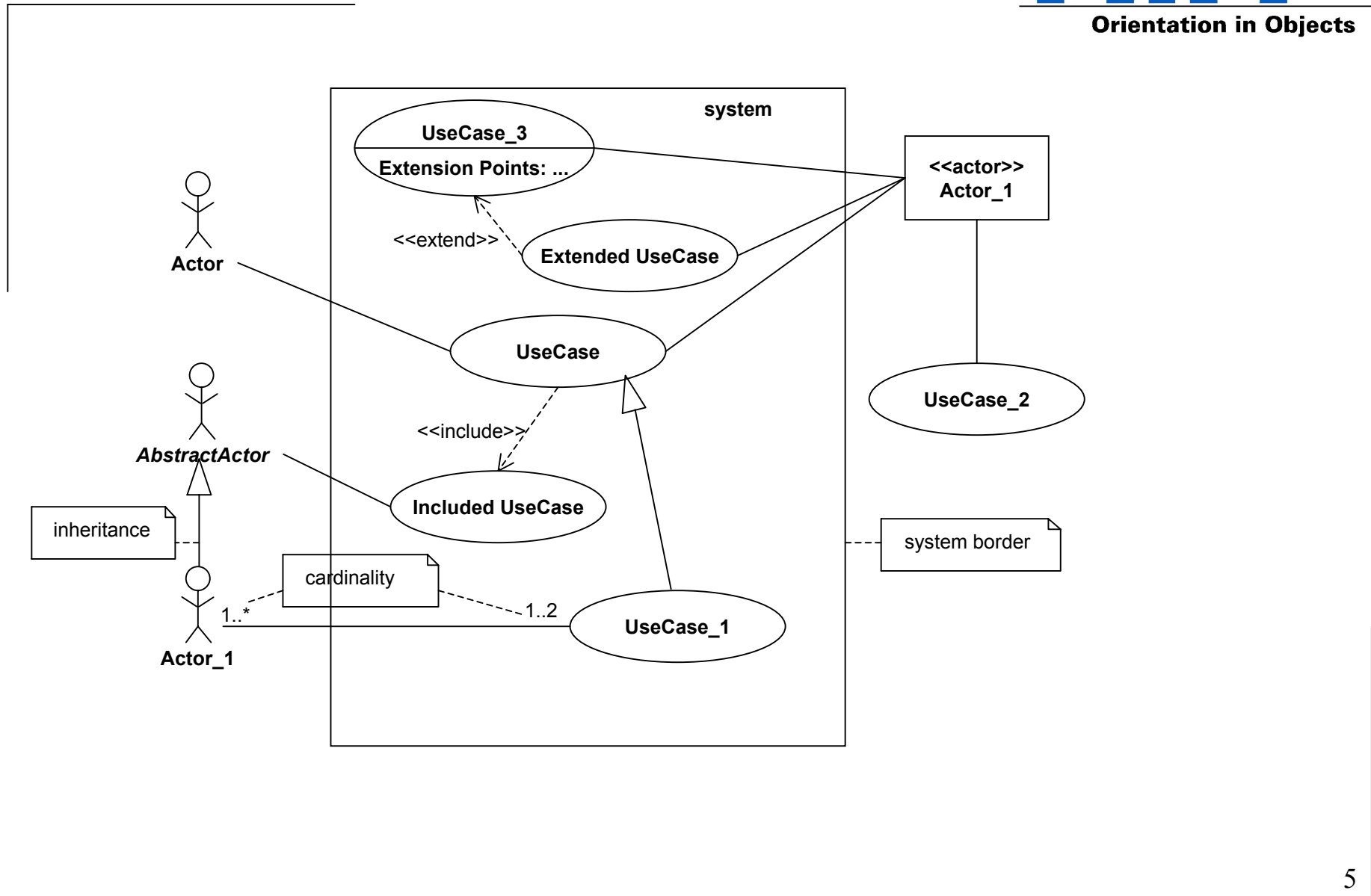

Activity Diagram

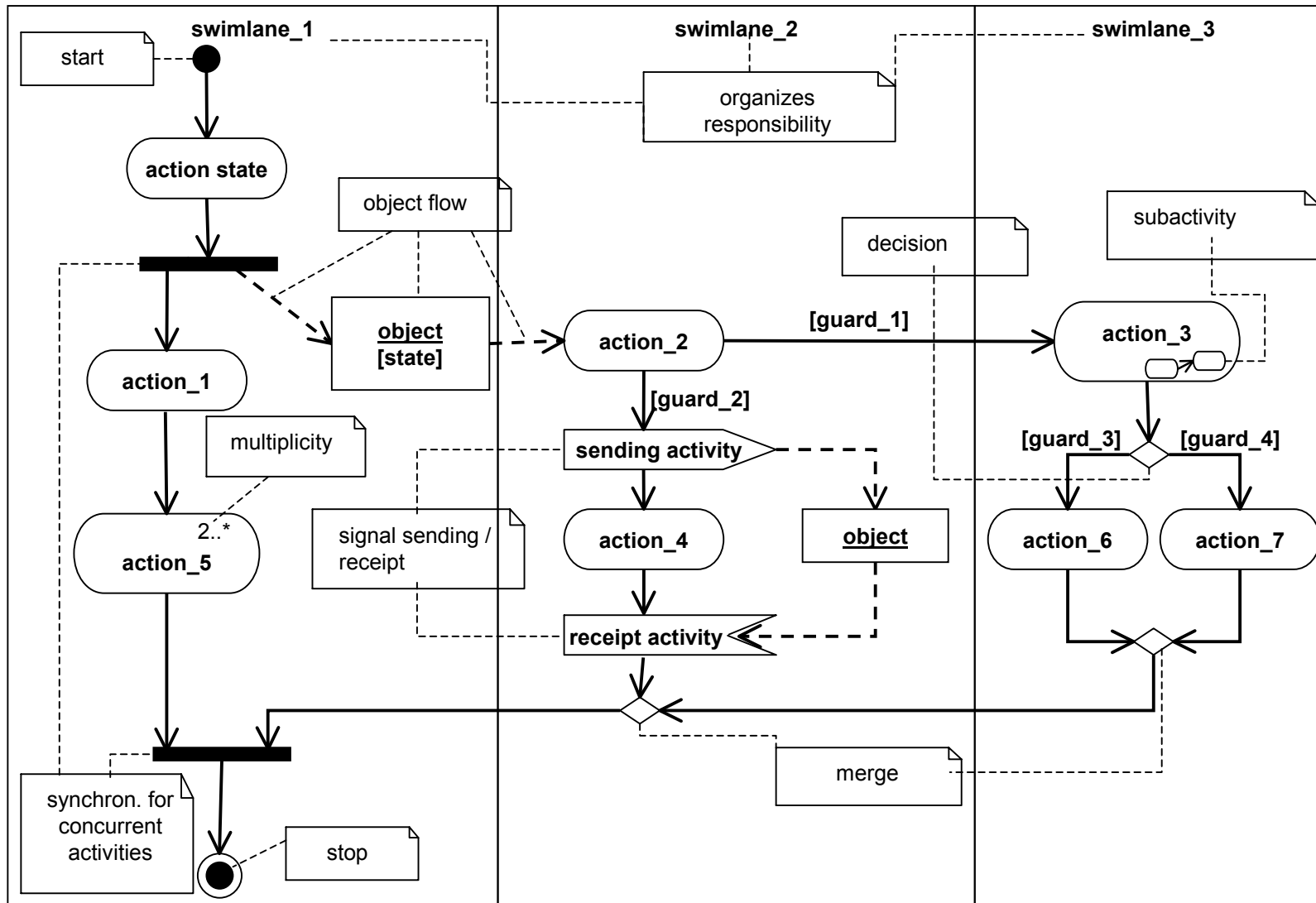

Statechart Diagram

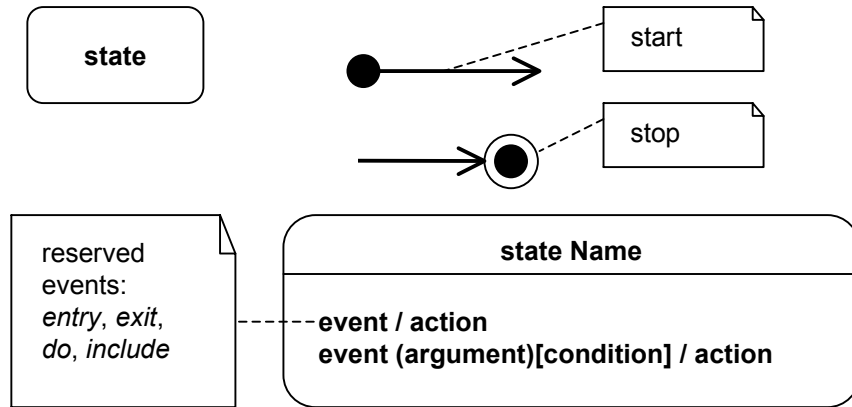

optionally:
event(argument) [condition]?
or only
[condition]

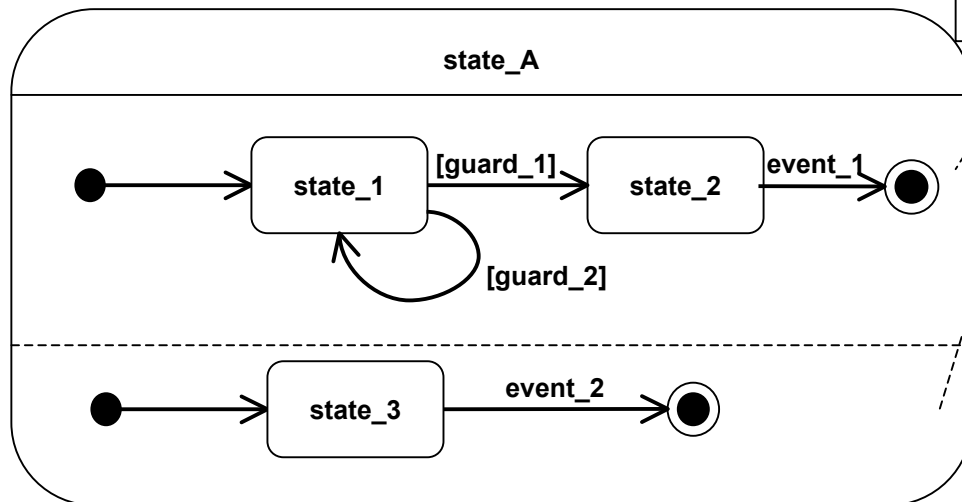
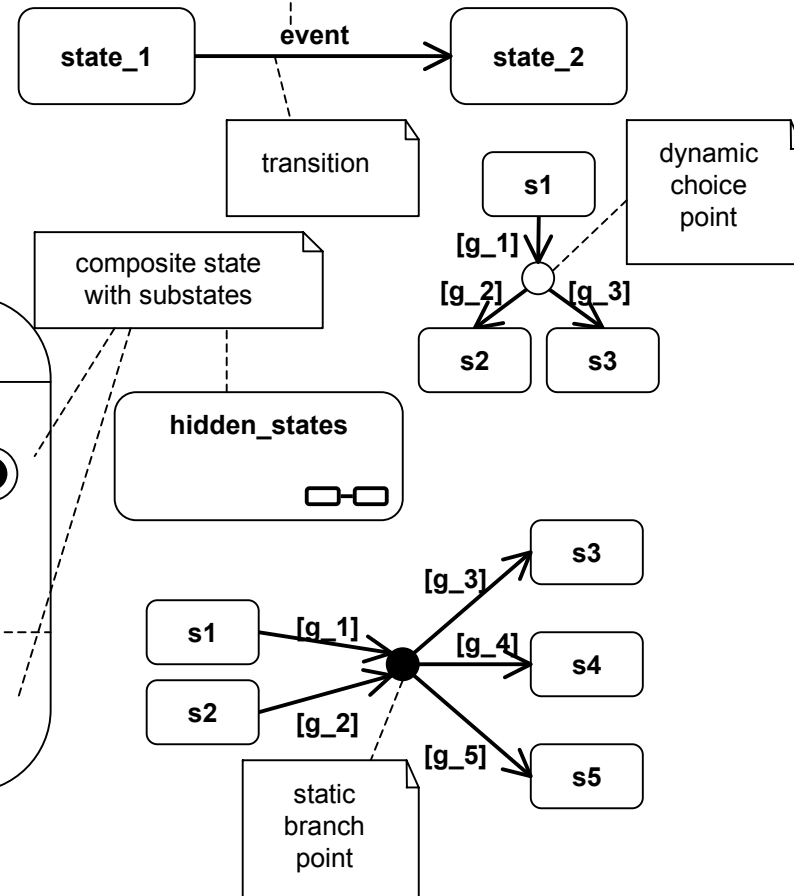

Sequence Diagram

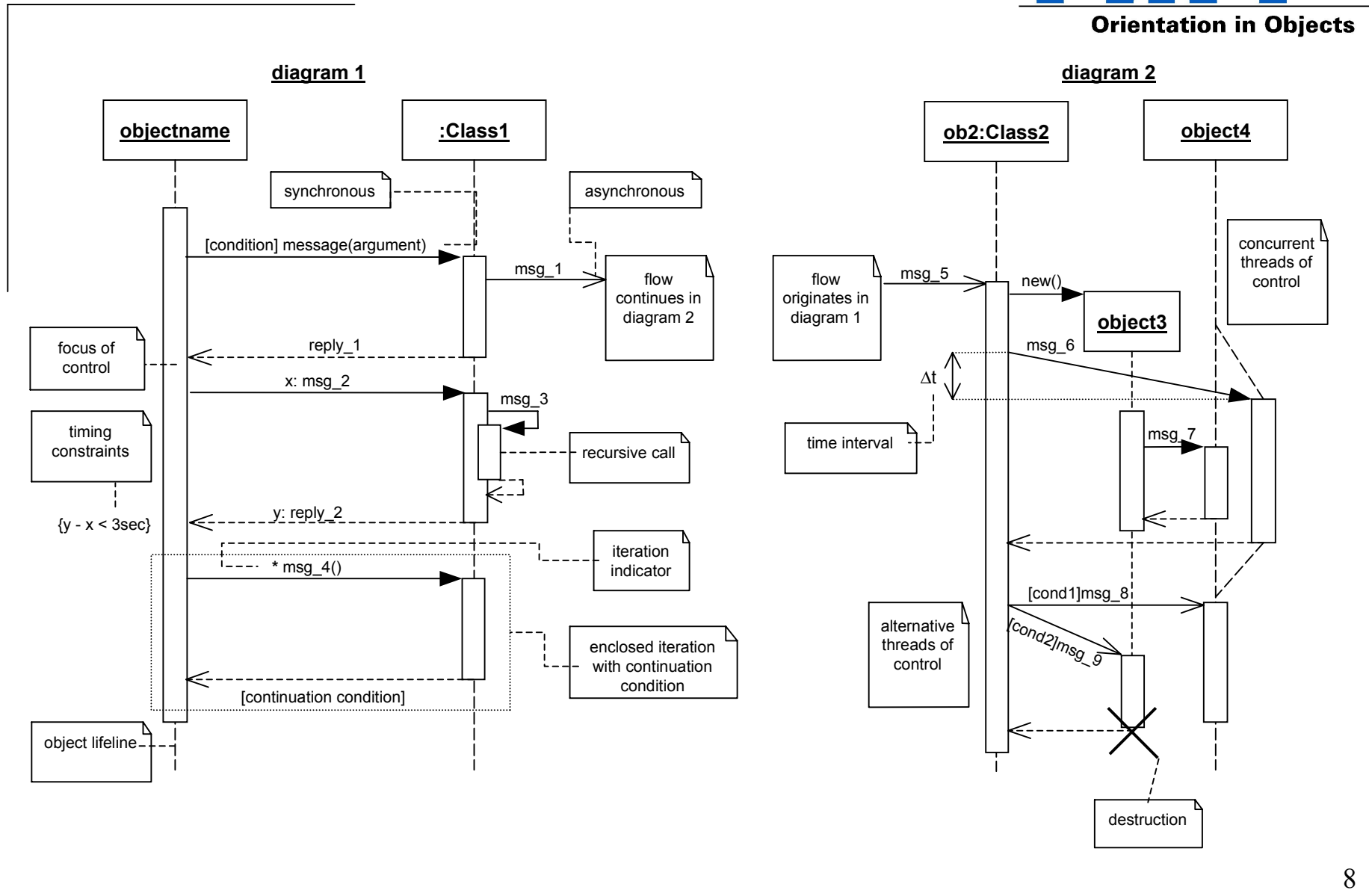

Collaboration Diagram

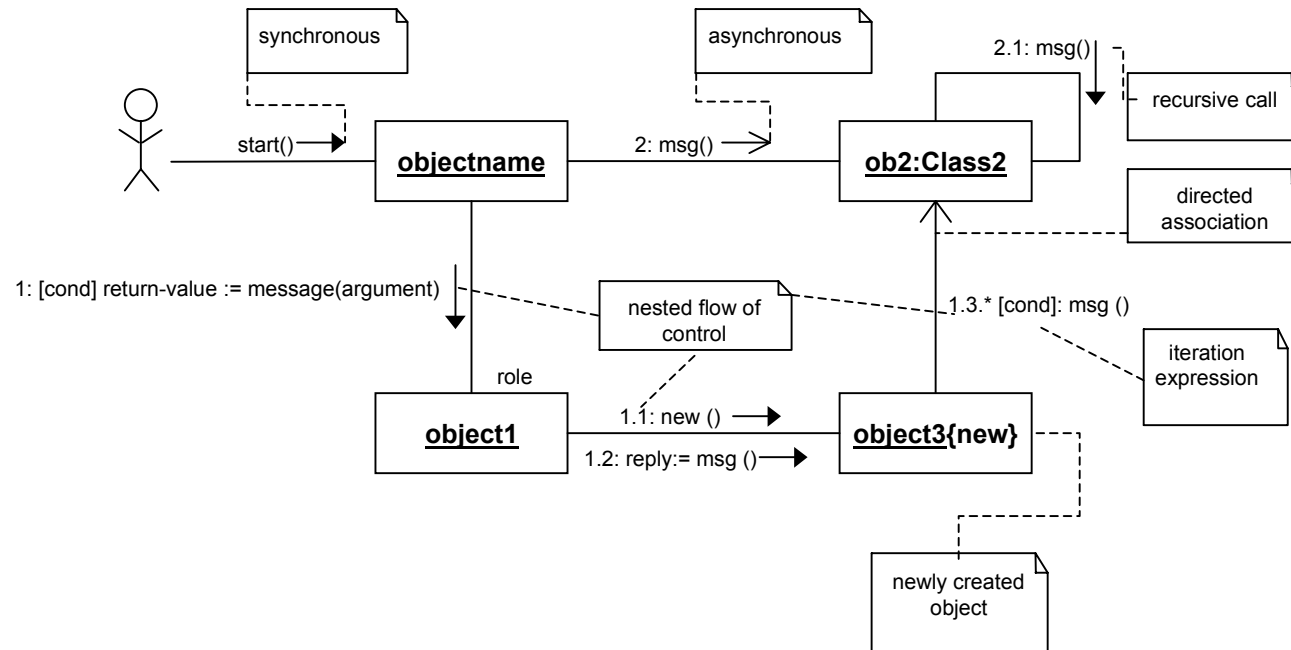

Component Diagram

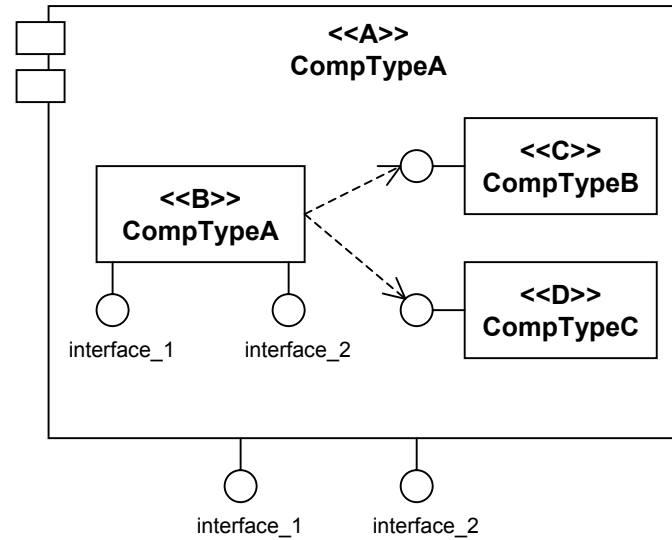
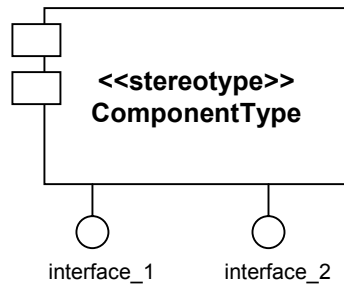

Deployment Diagram

